

HYDRAULICS

Hydraulics is study in science about liquid, the studies focus on their behaviors and response to mechanical forces and how this can be used in Engineering. It concerned with the conveyance of liquid through pipes and channel.

The following few term used in Hydraulics.

Mass:- It is a measure of the amount of material in an object, being directly related to the number and type of atoms present in the object. Mass does not change with a body's position, movement or alteration of its shape, unless material is added or removed.

Weight:- It is the gravitational force acting on a body mass.

1. Density or Mass Density:- It is the ratio of mass per unit volume of liquid. It is denoted by ρ (rho).

$$\rho = \frac{\text{Mass}}{\text{Volume}} \quad (\text{Unit} = \text{kg/m}^3)$$

Density of water is maximum at 4°C is 1000kg/m³

2. Specific weight:- The weight of a substance per unit volume is called specific weight. It is denoted by ω (omega).

$$\omega = \frac{\text{weight}}{\text{volume}} \quad (\text{Unit} = \text{N/m}^3)$$

Specific weight of water is 9.81 X 10³ N/m³

3. Specific volume:- It is defined as volume per unit mass of fluid. It is related to solids, liquid and gasses. It is denoted by (v).

$$v = \frac{\text{Volume}}{\text{Mass}} \quad (\text{Unit} = \text{m}^3/\text{kg})$$

4. Specific Gravity :- It is the ratio between the density on an object and a reference of substance. Usually our reference substance is water which always has a density 1gm/cm³.

5. Surface Tension:- The surface tension of liquid is its property, which enable it to resist tensile stress. It is due to cohesion between the molecules at surface of a liquid.

6. Viscosity:- It is that property of a liquid by virtue of which it offers resistance to the movement of one layer of liquid over an adjacent layer. It control the rate of flow of the liquid. The SI unit of Kinematic viscosity in m²/s.

FLUID PRESSURE

Fluid:- Fluid is the substance which is capable of flowing.

Thus we shall define a fluid body as one which readily changes its shape under action of very small forces.

There are two kinds of fluid:

Ideal Fluid:- Those fluids which have no viscosity and surface tension and they are incompressible is called ideal fluid. As such for ideal fluid no resistance is encountered as the fluid moves.

Real Fluid:- Those fluids which are actually available in nature. These fluids possess the properties such as viscosity, surface tension and compressibility and therefore a certain amount of resistance when they are in motion.

Pressure:- Whenever a liquid is contained in vessel, it exerts force at all point on the sides and bottom of the contain. The force exerted is due to the weight of the liquid.

The force per unit area is called pressure.

$$P = \frac{F}{A}$$

It units are N/m^2 or Pascal.

Atmospheric Pressure:- It is the pressure due to the weight of air above the surface of the earth.

Its SI units Pascals(1 Pascals= $1N/m^2$)

Gauge Pressure:- It is the pressure in which the atmospheric pressure is taken as datum, generally this pressure is above the atmospheric pressure.

Absolute Pressure:- It is the algebraic sum of the atmospheric pressure and gauge pressure.

Fluid Pressure:- It is the pressure at some point within a fluid, such as water or air.

Fluid pressure occurs in one of two situations.

a) An open condition called “open channel flow”

- (i) The Ocean
- (ii) Swimming Pool
- (iii) The atmosphere

b) A closed condition, called “closed conduits.”

- (i) Water line
- (ii) Gas line

Measurement of the Fluid Pressure

It is divided into the following two ways:-

- (i) By balancing the liquid column (whose pressure is to be found out) by the same or another column. These are also called tube gauges to measure the pressure.
- (ii) By balancing the liquid column (whose pressure is to be found out) by the spring or dead weight. These are also called mechanical gauge to measure the pressure.

Mechanical Gauges:- These gauges widely used when a very high fluid pressure is to be measured, a mechanical gauge is best suited for the purpose.

Basically the following type gauges are used:-

- (i) Bourdon's tube pressure gauge
- (ii) Diaphragm pressure gauge
- (iii) Dead weight pressure gauge

Bourdon's tube pressure gauge:

Basic Principle:

When an elastic transducer (bourdon tube in this case) is subjected to a pressure, it deflects. This deflection is proportional to the applied pressure when calibrated.

Description of Bourdon tube Pressure Gauge:

An elastic transducer, that is bourdon tube which is fixed and open at one end to receive the pressure which is to be measured. The other end of the bourdon tube is free and closed. The cross-section of the bourdon tube is elliptical. The bourdon tube is in a bent form to look like a circular arc. To the free end of the bourdon tube is attached an adjustable link, which is in turn connected to a sector and pinion as shown in diagram. To the shaft of the pinion is connected a pointer which sweeps over a pressure calibrated scale.

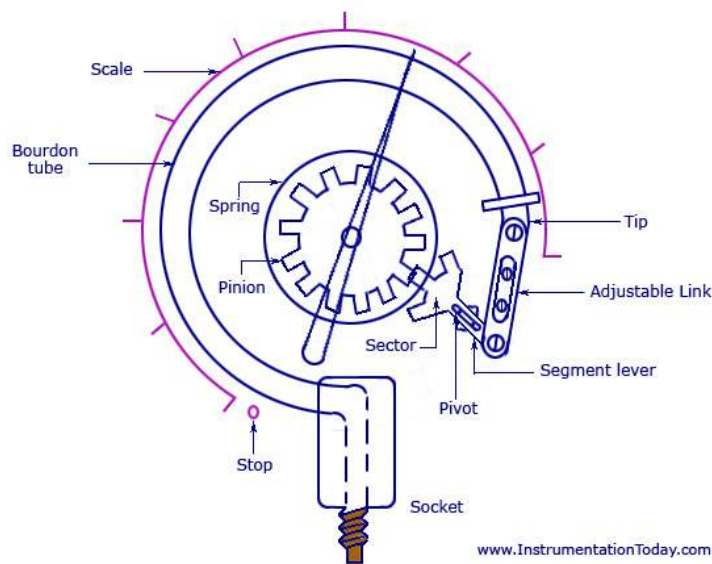

Bourdon Tube Pressure Gauge

Operation:-

The pressure to be measured is connected to the fixed open end of the bourdon tube. The applied pressure acts on the inner walls of the bourdon tube. Due to the applied pressure, the bourdon tube tends to change in cross – section from elliptical to circular.

This tends to straighten the bourdon tube causing a displacement of the free end of the bourdon tube.

This displacement of the free closed end of the bourdon tube is proportional to the applied pressure. As the free end of the bourdon tube is connected to a link – section – pinion arrangement, the displacement is amplified and converted to a rotary motion of the pinion.

As the pinion rotates, it makes the pointer to assume a new position on a pressure calibrated scale to

indicate the applied pressure directly. As the pressure in the case containing the bourdon tube is usually atmospheric, the pointer indicates gauge pressure.

Advantages of Bourdon tube pressure gauge:

- i) These Bourdon tube pressure gauges give accurate results.
- ii) Bourdon tube cost low.
- iii) Bourdon tube are simple in construction.
- iv) They can be modified to give electrical outputs.
- v) They are safe even for high pressure measurement.
- vi) Accuracy is high especially at high pressures.

Limitations of bourdon tube pressure gauge:

- i) They respond slowly to changes in pressure
- ii) They are subjected to hysteresis.
- iii) They are sensitive to shocks and vibrations.
- iv) Amplification is a must as the displacement of the free end of the bourdon tube is low.
- v) It cannot be used for precision measurement.

Tube Gauges:

The devices used for measuring the fluid pressure, by tube gauges, are:

1. Piezometer tube and
2. Manometer.

Piezometer tube

A piezometer is a simplest form of manometer, used for measuring moderate pressures. It consists of a tube, open at one end to the atmosphere, in which the liquid can rise freely without overflow. The height, to which the liquid rises up in the tube, gives the pressure head directly.

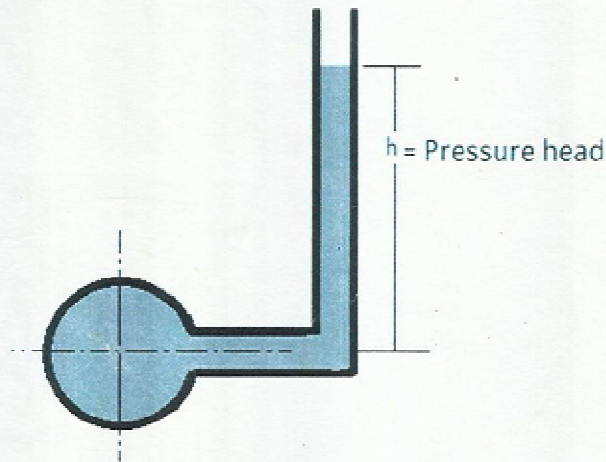

Manometer

A Manometer is a improved type of a piezometer tube. With the help of a Manometer, we can measure comparatively high pressures and negative pressures also. Following are the few types of Manometers.

1. Simple manometer
2. Micro manometer
3. Differential manometer
4. Inverted Differential manometer

Simple manometer

We know that a Piezometer is not suitable for the measurement of high pressure or negative pressures. The piezometer tube was improved so as to measure high pressure as well as negative pressures. This improved piezometer is known as a Manometer.

A simple manometer, in its simplest form, is a tube bent in U-shape; one end of which is attached to the gauge point and the other is open to the atmosphere.

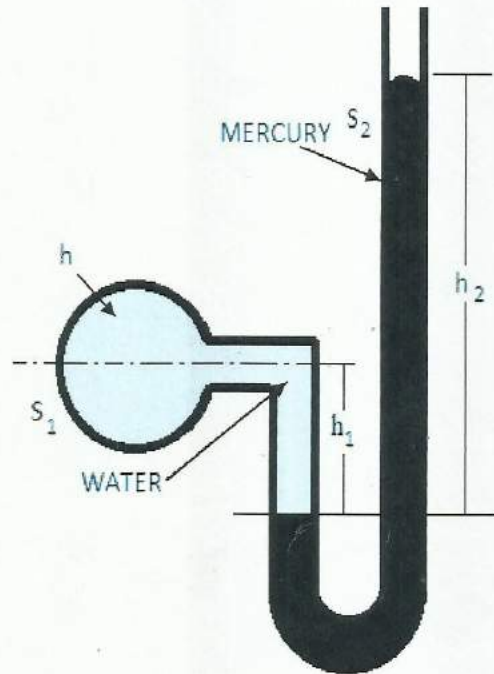

The liquid in the bent tube or simple manometer is generally, mercury which is 13.6 times heavier than water. Hence it is suitable for measuring high pressures also.

Now consider a simple manometer connected to a pipe containing a light liquid under a high pressure. The high pressure in the pipe will force the heavy liquid, in the left limb of the U-tube, to move downward. This downward movement of the heavy liquid in the left limb will cause a corresponding rise of the heavy liquid, in the right limb. The horizontal surface, at which the heavy and light liquid meet in the left limb is known as a common surface or datum line. Let Z-Z be the datum line, in this case,

Let, h_1 = Height of the light liquid in the left limb above the common surface in cm.

h_2 = Height of the heavy liquid in the right limb above the common surface in cm.

h = Pressure in the pipe, expressed in terms of head of water in cm.

s_1 = Specific gravity of light liquid.

s_2 = Specific gravity of heavy liquid.

Now,

Pressure in the left limb above the datum line:

$$= h + s_1 h_1 \text{ cm of water} \quad \dots\dots\dots(i)$$

And Pressure in the left limb above the datum line:

$$= s_2 h_2 \text{ cm of water} \quad \dots\dots\dots(ii)$$

Now both side (in right limb and left limb) pressure above the datum line is equal.

So, equating these two pressures (i) and (i) :

$$h + s_1 h_1 = s_2 h_2$$

$$\mathbf{h = (s_2 h_2 - s_1 h_1) \text{ cm of water.}}$$

If a negative pressure is to be measured by a simple manometer, the same can also be easily measured.

In this case, the negative pressure in pipe will suck the light liquid which will pull-up the heavy liquid in the left limb of the U-tube. This upward movement of the heavy liquid, in the left limb, will cause a corresponding fall of the liquid in the right limb.

In this case the datum line z-z may be considered to correspond with the top level of the heavy liquid in the right column.

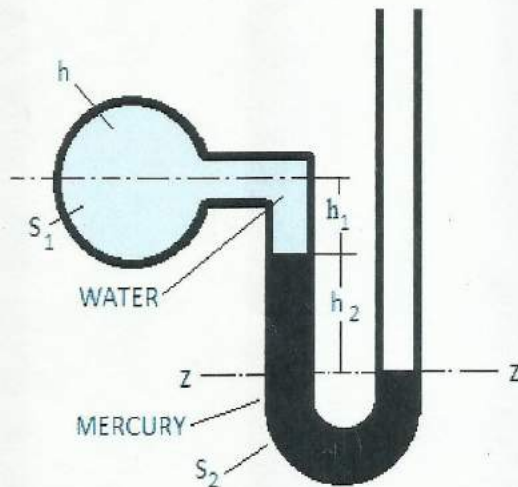

Now the pressure in the left limb above the datum line:

$$= h + s_1 h + s_2 h_2 \quad \dots\dots\dots(i)$$

And pressure in the right limb above the datum line:

$$= 0 \quad \dots\dots\dots(ii)$$

Now both side (in right limb and left limb) pressure above the datum line is equal.

So, equating these two pressures (i) and (i) :

$$h + s_1 h + s_2 h_2 = 0$$

$$s_1 h + s_2 h_2 = -h$$

$$h = - (s_1 h + s_2 h_2) \text{ cm of water.}$$

HYDROSTATICS

The term hydrostatics means the study of pressure, exerted by a liquid at rest.

The force acting on the body in hydraulics is called **the total pressure**. A fluid at rest no tangential forces exist, the total pressure acts in the direction, normal to the surface. The point of application of total pressure on the surface is known as **the centre of pressure**.

Total pressure on an immersed surface:

The position of an immersed surface may be:-

- (i) Horizontal
- (ii) Vertical
- (iii) Inclined

1. Total pressure on a Horizontal immersed surface:

Let $w =$ Sp. Weight of the liquid
 $A =$ Area of the immersed the surface

$\bar{X} =$ Depth of the horizontal surface from the liquid level.

so that $P = w.A.\bar{X}$

2. Total pressure on a Vertically immersed surface:

Let $w =$ Sp. Weight of the liquid
 $A =$ Area of the immersed the surface

$\bar{X} =$ Depth of centre of gravity of the surface from the liquid level

so that $P = w.A.\bar{X}$

3. Total pressure on a inclined immersed surface:

Let $w =$ Sp. Weight of the liquid
 $A =$ Area of the immersed the surface

$\bar{X} =$ Depth of centre of gravity of the surface from the liquid level

so that $P = w.A.\bar{X}$

BUOYANCY AND FLOATATION

Buoyancy:- The tendency of a fluid to uplift a submerged body, because of the upward thrust of the fluid, is known as the force of buoyancy. It is always equal to the weight of the fluid displaced by the body.

Centre of buoyancy:- The centre of buoyancy is the point, through which the force of buoyancy is supposed to act. It is always the centre of gravity of the volume of the liquid displaced. In other word the centre of buoyancy is the centre of area of the immersed section.

Metacentre:- Whenever a body, floating in a liquid, is given a small angular displacement, it starts oscillating about some point. This point, about which the body starts oscillating, is called metacentre.

Principle of floatation:- The weight of a body floating in a fluid is equal to the buoyant force which in turn is equal to the weight of the fluid displaced by the body.

When a submerged or a floating body is given a slight angular displacement, it may either of the following three conditions of equilibrium developed:-

- (i) Stable Equilibrium
- (ii) Unstable Equilibrium
- (iii) Neutral Equilibrium

Stable Equilibrium: - A body is said to be in a stable equilibrium, if it return back its original position, when given a small angular displacement.

This happens when the metacentre (M) is higher than the centre of gravity (G) of the floating body

Unstable Equilibrium: - A body is said to be in a unstable equilibrium, if it does not return back its original position and heel farther away, when given a small angular displacement.

This happens when the metacentre (M) is lower than the centre of gravity (G) of the floating body.

Neutral Equilibrium: - A body is said to be in a neutral equilibrium, if it occupies a new position and remain at rest in this new position, when given a small angular displacement.

This happens when the metacentre (M) coincides with the centre of gravity (G) of the floating body.

HYDRO – KINEMATICS

The subject kinematics deals with the study of velocity and acceleration of the fluid particles without taking into consideration any force or energy.

Types of fluid flow:- Fluid flow consists of flow of number of small particles grouped together. These particles may group themselves in verity of ways and type of flow depends on how these groups behave.

The following are the important types or classification of fluid flow.

1. Steady and Unsteady flow
2. Uniform and Non-Uniform flow
3. One, Two and three dimensional flow
4. Compressible and Incompressible flow
5. Rotational and Irrotational flow
6. Laminar and Turbulent flow

Equation of continuity of a liquid flow:

If a liquid is continuously flowing through a pipe or a channel the quantity of liquid passing per second is the same at all section. This is known as the Equation of continuity of a liquid flow.

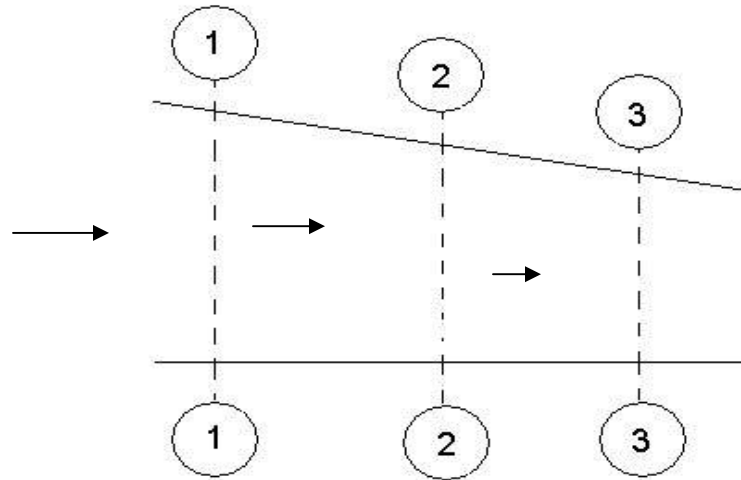

Consider a tapering pipe through which some liquid is flowing as shown in figure.

- Let a_1 = area of the pipe, at section 1-1
 v_1 = velocity of the liquid at section 1-1
 a_2 = area of the pipe, at section 2-2
 v_2 = velocity of the liquid at section 2-2
 a_3 = area of the pipe, at section 3-3
 v_3 = velocity of the liquid at section 3-3

Weight of the liquid passing through section 1-1
 $Q_1 = wa_1v_1$ (i)

Similarly, Weight of the liquid passing through section 2-2
 $Q_2 = wa_2v_2$ (ii)

And Weight of the liquid passing through section 3-3
 $Q_3 = wa_3v_3$ (iii)

Since weight of the liquid passing through the sections 1-1, 2-2 and 3-3 is the same, therefore $Q_1 = Q_2 = Q_3$

or $wa_1v_1 = wa_2v_2 = wa_3v_3$
 or $a_1v_1 = a_2v_2 = a_3v_3$ and so on....

This is also known as equation of continuity.

Energy of liquid in motion:- Energy is the capacity to do work. Though the energy exists in many forms, yet the some following are:

Potential Energy:- It is energy possessed by a liquid particles by virtue of its position.
 $PE = mgh$

Kinetic Energy:- It is energy possessed by a liquid particles by virtue of its velocity.
 $KE = \frac{1}{2} mv^2$

Pressure Energy:- It is energy possessed by a liquid particles by virtue of its pressure.
 Pressure / sp. weight of liquid

Total Energy of a liquid particles in motion:

The total energy of a liquid particle, in motion, is the sum of its potential energy, kinetic energy and pressure energy.

$$\text{Total Energy (E)} = Z + \frac{V^2}{2g} + \frac{P}{w} \text{ m kg / kg of liquid.}$$

BERNOULI' THEORUM

It states that in a study flow of an ideal incompressible fluid in which there is continuous connection between all the particles, and no energy is added or taken out between any point, the total energy or total Head (H) at any one point is equal to total energy or the total Head at any other point on a streamline.

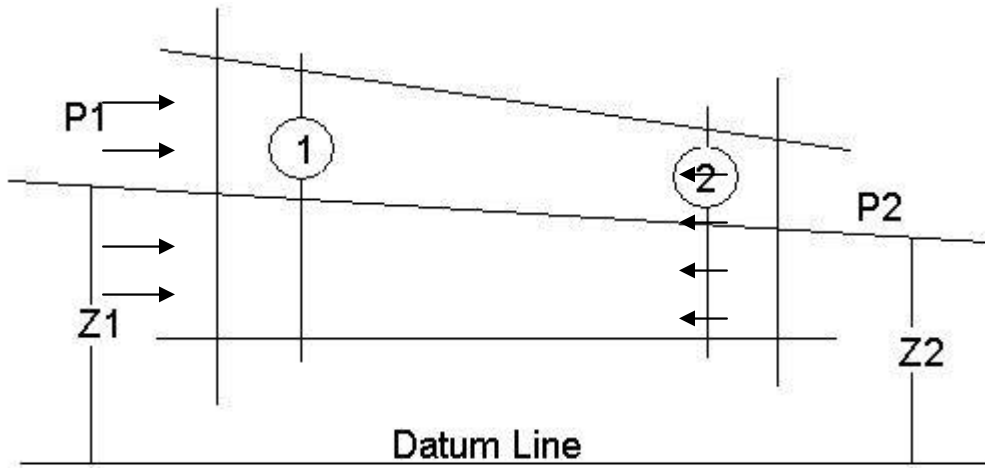

$$Z_1 + \frac{(V_1)^2}{2g} + \frac{P_1}{w} = Z_2 + \frac{(V_2)^2}{2g} + \frac{P_2}{w}$$

Where Z_1 = potential energy of section 1-1 Z_2 = potential energy of section 2-2

$\frac{(V_1)^2}{2g}$	= Kinetic energy of section 1-1	$\frac{(V_2)^2}{2g}$	= Kinetic energy of section 2-2
$\frac{P_1}{w}$	= Pressure energy of section 1-1	$\frac{P_2}{w}$	= Pressure energy of section 2-2

Limitation of Bernoulli Theorem:-

1. The equation is applicable for steady flow, incompressible fluids.
2. The losses of energy can not be accountable such as due to viscosity and some kinetic energy of fluid convert into heat energy.
3. While driving the equation it was assumed that no external force except gravity force is acting on the fluid.
4. If the liquid is flowing in a curved path, the energy due to centrifugal force should be taken into account.

FLOW THROUGH ORIFICES

An opening in a vessel, through which the liquid flows out, is known as orifice. This hole or opening is called an orifice.

An orifice may be in a vertical side of the vessel or in the horizontal base.

Types of orifice:-

1. According to size:
(i) Small size (ii) large size
2. According to shape:
(i) Circular shape (ii) rectangular shape (iii) triangular shape
3. According to shape of the edge:
(i) Sharp edge orifice (ii) bell mouthed orifice
4. According to nature of discharge:
(i) Fully submerged orifice (ii) Partially submerged orifice

Hydraulics Coefficient:- The following these coefficient are known as hydraulics coefficient or orifice coefficient.

1. Coefficient of contraction
2. Coefficient of velocity
3. Coefficient of discharge

1. Coefficient of contraction:- The ratio of area of the jet at vena contracta, to the area of the orifice is known as Coefficient of contraction.

$$C_C = \frac{\text{Area of jet at vena contracta}}{\text{Area of orifice}}$$

The avg. value of C_C is about 0.64.

2. Coefficient of velocity:- The ratio of actual velocity of the jet at vena contracta, to the theoretical velocity is known as Coefficient of velocity.

$$C_v = \frac{\text{Actual velocity of vena contracta}}{\text{Theoretical velocity}}$$

The avg. value of C_v is about 0.97

3. Coefficient of discharge:- The ratio of actual discharge through an orifice to the theoretical discharge is known as Coefficient of discharge.

$$C_d = \frac{\text{Actual discharge}}{\text{Theoretical discharge}}$$

It is also $C_d = C_v \times C_C$

The avg. value of C_d is about 0.62

Discharge through a large rectangular orifice: -

$$\frac{2}{3} C_d b \sqrt{2g} [(H_2)^{3/2} - (H_1)^{3/2}]$$

Where H_1 = Height of liquid, above the top of the orifice.
 H_2 = Height of liquid, above the bottom of the orifice.
 b = breadth of the orifice.
 g = gravity.
 C_d = Coefficient of discharge.

Time of emptying a rectangular tank through an orifice at its bottom:-

$$T = \frac{2.A \sqrt{H_1}}{C_d a \sqrt{2g}}. \quad \text{Second.}$$

Where T = Time in sec.
 A = Area of the tank.
 a = Area of orifice.
 H_1 = Initial Height of the liquid.
 C_d = Coefficient of discharge.

MOUTH-PIECES

If a short pipe shall be fitted to an orifice, it will increase the value of Coefficient of discharge. Such a pipe whose length is generally more than 2 times of the diameter of an orifice, is fitted to an orifice is known as mouthpieces. It may be fitted externally or internally.

Types of the mouth-pieces as follows:-

1. According to the position of the mouth-pieces.
 - (i) Internal mouth-piece
 - (ii) External mouth- piece
2. According to the shape of mouth-piece.
 - (i) Cylindrical mouth-piece
 - (ii) convergent mouth-piece
 - (iii) Convergent-Divergent mouth-piece.
3. According to nature and discharge.
 - (i) Mouth-piece running full
 - (ii) Mouth-piece running free

Discharge through an External Mouth-Piece:

$$Q = C_d \cdot a \cdot \sqrt{2g \cdot H} \quad \text{or} \quad 0.855 \cdot a \cdot \sqrt{2g \cdot H}$$

Where
Q = discharge
a = area of the mouth- piece.
H = height of liquid above the mouth-piece.
C_d = Coefficient of discharge.

Discharge through an Internal Mouth-Piece:

(i) If mouth-piece running free:

$$Q = C_d \cdot a \cdot \sqrt{2g \cdot H} \quad \text{or} \quad 0.5 \cdot a \cdot \sqrt{2g \cdot H}$$

(ii) If mouth-piece running full:

$$Q = C_d \cdot a \cdot \sqrt{2g \cdot H} \quad \text{or} \quad 0.855 \cdot a \cdot \sqrt{2g \cdot H}$$

Where
Q = discharge
a = area of the mouth- piece.
H = height of liquid above the mouth-piece.
C_d = Coefficient of discharge.

Discharge through an Convergent Mouth-Piece:

$$Q = a \cdot \sqrt{2g \cdot H}$$

Water Wheel

A water wheel is a machine for converting the energy of free-flowing or falling water into useful forms of power.

A water wheel consists of a large wooden or metal wheel, with a number of blades or buckets arranged on the outside rim forming the driving surface. Most commonly, the wheel is mounted vertically on a horizontal axle, but the tub or Norse wheel is mounted horizontally on a vertical shaft. Vertical wheels can transmit power either through the axle or via a ring gear and typically drive belts or gears; horizontal wheels usually directly drive their load.

Water wheels were still in commercial use well into the 20th century, but they are no longer in common use. Prior uses of water wheels include milling flour in gristmills and grinding wood into pulp for papermaking, but other uses include hammering wrought iron, machining, ore crushing and pounding fiber for use in the manufacture of cloth.

Some water wheels are fed by water from a mill pond, which is formed when a flowing stream is dammed. A channel for the water flowing to or from a water wheel is called a mill race (also spelled millrace) or simply a "race", and is customarily divided into sections. The race bringing water from the mill pond to the water wheel is a **head race**; the one carrying water after it has left the wheel is commonly referred to as a **tail race**.

John Smeaton's scientific investigation of the water wheel led to significant increases in efficiency in the mid to late 18th century and supplying much needed power for the Industrial Revolution.

Water wheels began being displaced by the smaller, less expensive and more efficient turbine developed by Benoît Fourneyron, beginning with his first model in 1827. Turbines are capable of handling high *heads*, or elevations, that exceed the capability of practical sized waterwheels.

The main difficulty of water wheels is their dependence on flowing water, which limits where they can be located. Modern hydroelectric dams can be viewed as the descendants of the water wheel as they too take advantage of the movement of water downhill.

TURBINE

water turbine is a rotary engine that takes energy from moving water

Water turbines were developed in the 19th century and were widely used for industrial power prior to electrical grids. Now they are mostly used for electric power generation. They harness a clean and renewable energy source.

Turbine may be broadly classified into the following two main groups:-

1. **Impulse Turbine**
2. **Reaction turbine**

1. Impulse Turbine:

In such turbine, the entire available energy of water is first converted into kinetic energy, by passing it through nozzle which is kept closed to the runner. The water enters the running wheel in the form of the jet which impinges on the buckets, fixed to the outer periphery of the wheel

Pelton Wheel or Pelton turbine is one of the examples of Impulse turbine.

The main parts of a Pelton turbine are:

1. Nozzle and flow regulating arrangement (spear),
2. Runner and bucket,
3. Casing, and
4. Breaking jet.

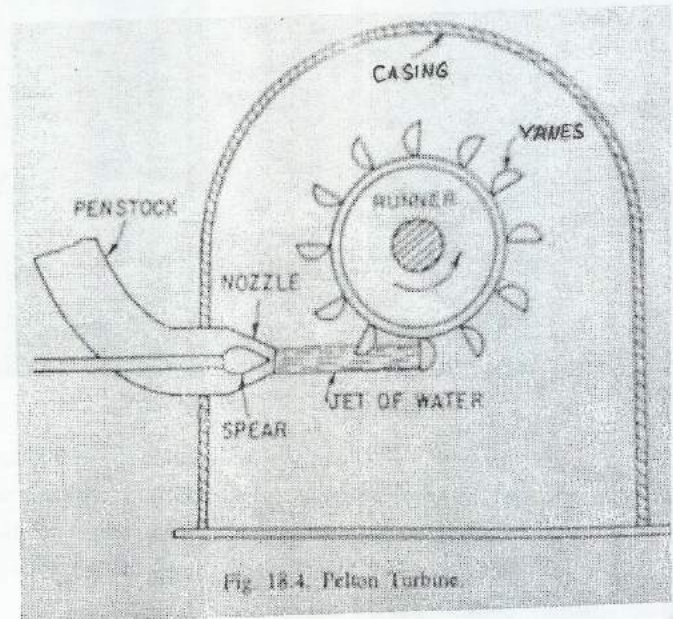
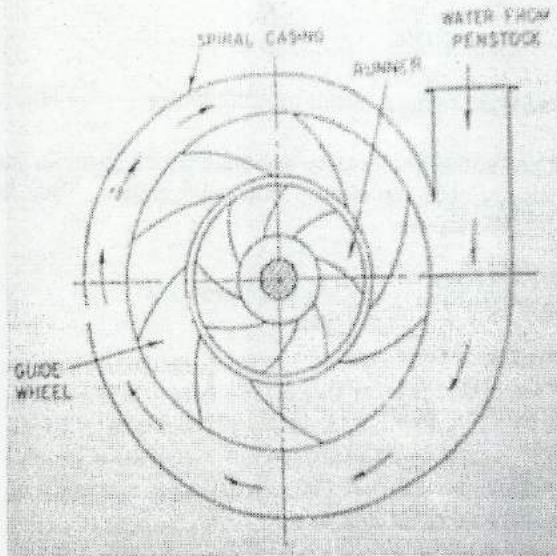

Fig 18.4. Pelton Turbine

2. Reaction turbine:

In a reaction turbine, the water enters the wheel under pressure and flows over the vanes. As the water flowing over the vanes, is under pressure, therefore the wheel of the turbines run full and may be submerged below the tail race or may discharge into the atmosphere. The pressure head of water, while flowing over the vanes, is converted into velocity head and finally to the atmospheric pressure, before leaving the wheel.



Main parts of a Radial Reaction Turbine

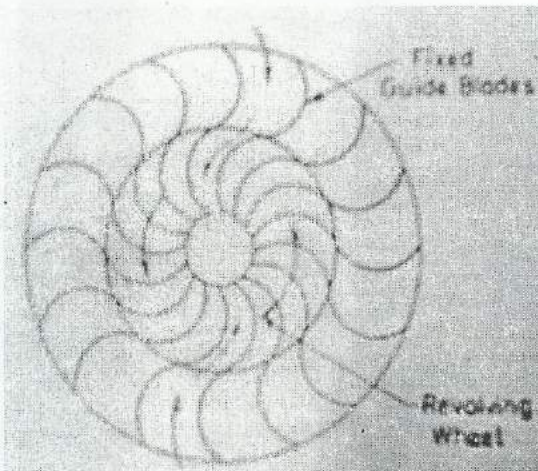

Inward flow reaction turbine

The inward flow reaction turbine, as the name indicates, is that reaction turbine in which the water enters the wheel at the outer periphery and when flows inward over the vanes (toward the centre of the wheel)

An inward flow reaction turbine, consist of fixed guide blade, which guide the water to enter in to the revolving wheel at correct angle for the shockless entry of the water. The water, while gliding over the vans, exerts some force on the revolving wheel, to which the vans are fixed. This force causes the revolving to revolve.

The outward flow reaction turbine, as the name indicates, is that reaction turbine in which the water enters at the centre of the wheel and then flows of water over the vanes (toward the outer periphery of the wheel)

An outward flow reaction turbine, consists of fixed guide blades which guide the water to enter in to the revolving wheel at correct angle for shockless entry of water. The water, while gliding over the vans, exerts some force on the revolving wheel, to which the vans

at fixed. This force causes the revolving to revolve.

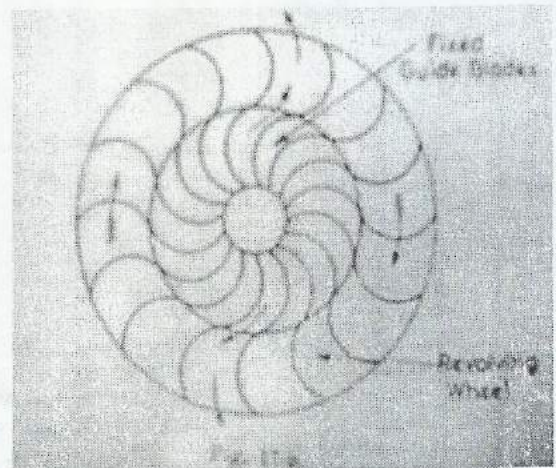

Outward Reaction turbine

Difference between an Impulse Turbine and Reaction Turbine:

S.No.	Impulse Turbine	Reaction Turbine
1.	The entire available energy of the water is first converted into kinetic energy.	The available energy of the water is not converted from one form into another form.
2.	The water flows through the nozzle and impinges on the bucket, which are fixed to the outer periphery of the wheel.	The water is guided by the blades to flow over the moving vanes.
3.	The water impinges on the bucket with kinetic energy.	The water water is glides over the moving blades with pressure energy.
4.	The pressure of the flowing water remains constant and is equal to the atmospheric pressure.	The pressure of the flowing water is reduced after gliding over the blades.
5.	The water may be admitted over a part of the circumference or over whole circumference of the wheel.	The water must be admitted over the whole circumference of the wheel.
6.	It is possible to regulate the flow without losses.	It is not possible to regulate the flow without losses.
7.	The work is done only by the change in the kinetic energy of the jet.	The work is done partly by the change in the velocity head but almost entirely by the change in pressure head.

PERFORMANCE OF TURBINE

Sometimes we have to compare the performance of turbine, of different outputs and speed, working under different head.

This comparison will be much convenient, if we calculate the output of the turbine when the head of water is reduced to unity i.e. one meter.

We always study the following three characteristic of a turbine under unit head.

1. Unit Power
2. Unit Speed
3. Unit Discharge

1. Unit Power :- The power developed by a turbine, working under a head of one meter is known as unit power.

2. Unit Speed :- The speed of a turbine, working under a head of one meter is known as unit speed.

IMPACT OF JET

Whenever a jet of liquid strike on a fixed plate, the plate experiences some forces. This force is equal to the rate of change of momentum of the jet. If the plate is not fixed, it starts moving in the direction of the jet.

Force of jet impinging normally on a fixed plate:

$$F = \frac{\omega a V^2}{g} \text{ kg}$$

$$\begin{aligned} V &= \text{velocity of the jet in m/sec.} \\ a &= \text{cross-sectional area of the jet in m}^2 \\ \omega &= \text{mass} \end{aligned}$$

PUMP

PUMP:

A pump may be defined as a machine when driven, from some external source, lifts water or some other liquid from a lower level to a higher level. In other words, a pump may be defined as a hydraulic machine, which converts mechanical energy into hydraulic energy (pressure energy).

Following are the important types of pump from the subject point of view:

1. Centrifugal Pump, and
2. Reciprocating Pump.

Centrifugal Pump:

The pump which raises water or a liquid from a lower level to a higher level by centrifugal force is known as a centrifugal pump.

In centrifugal pump, mechanical energy is fed into the shaft and water enters the impeller which increases the pressure energy of the outgoing liquid.

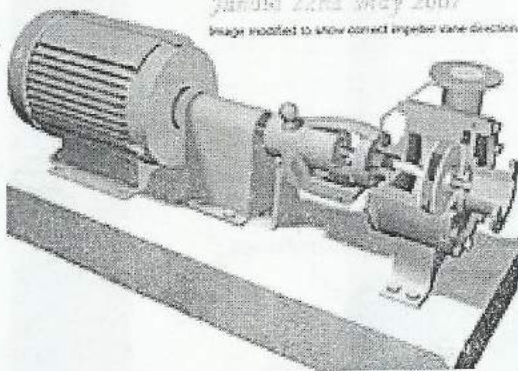

Main parts of Centrifugal Pump:

1. Impeller.
2. Casing.
3. Suction pipe with a foot valve and a strainer.
4. Delivery pipe.

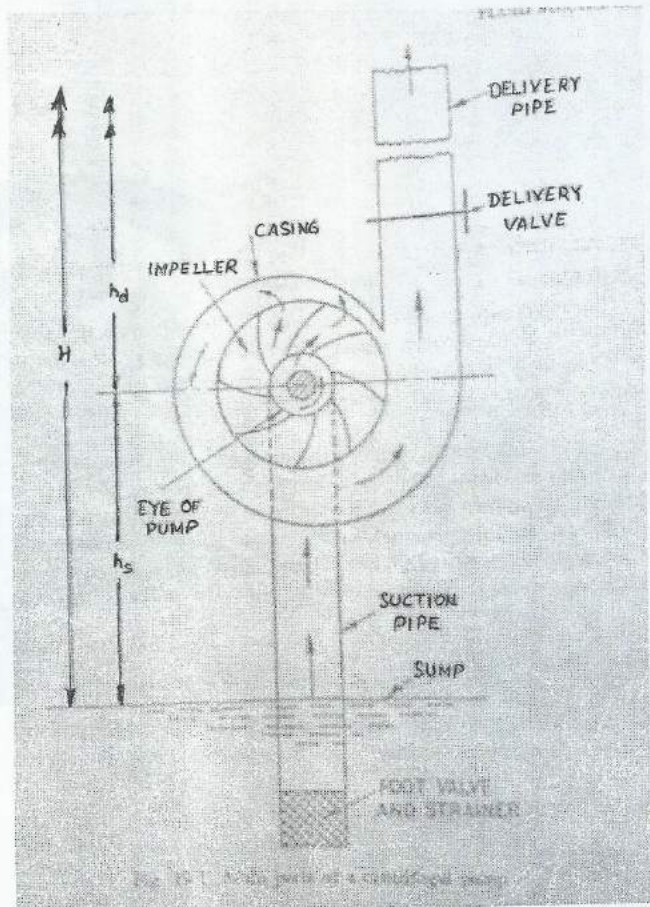

1. **Impeller:** The rotating part of centrifugal pump is called 'Impeller'. It consists of a series of backward curved vanes. The Impeller is mounted on a shaft which is connected to the shaft of an electric motor.
2. **Casing:** The casing of a centrifugal pump is similar to the casing of a reaction turbine. It is an air tight passage surrounding the impeller and is designed in such a way that the kinetic energy of the water discharged at the outlet of the impeller is converted into pressure energy before the water leaves the casing and enters the delivery pipe.
3. **Suction pipe with a foot valve and a strainer:** A pipe whose one end is connected to the inlet of the pump and other end dips into water in sumps known as suction pipe. A foot valve which is a non-return valve or one way type of valve is fitted at the lower end of suction valve. The foot valve only opens in the upward direction. A strainer is also fitted at the lower end of the suction valve.
4. **Delivery pipe:** A pipe whose one end is connected to the outlet of the pump and other end delivers the water at a required height is known as delivery pipe.

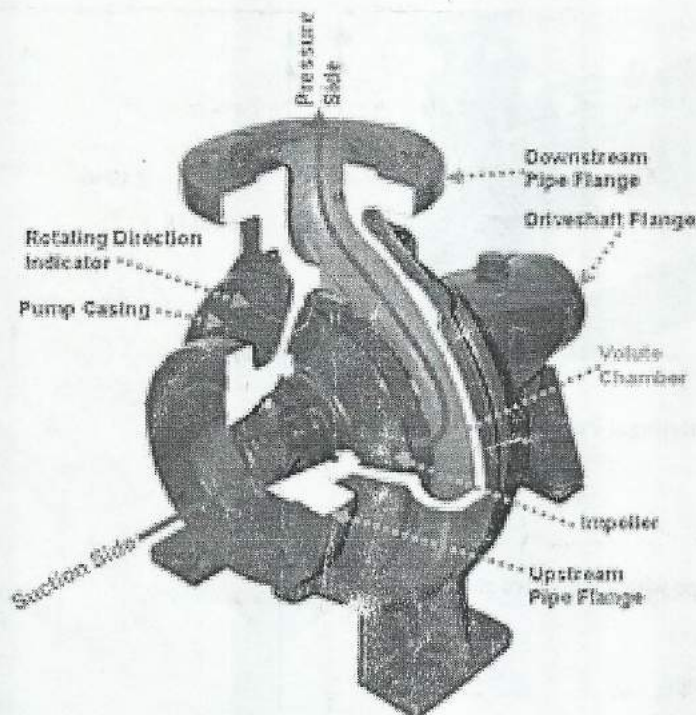

Working of a Centrifugal pump:

The action of a centrifugal pump is that of a reversed reaction turbine. In a centrifugal pump, the mechanical energy is fed into the shaft and water enters the impeller (attached to the rotating shaft) which increases the pressure energy of the outgoing fluid. The water enters the impeller radially and leaves the vanes axially.

Reciprocating Pump:

If mechanical energy converted into pressure energy by sucking the liquid into a cylinder in which a piston is reciprocating which exerts the thrust on the liquid and increase its hydraulic energy (pressure energy) the pump is known as Reciprocating pump.

A Reciprocating Pump is called a positive displacement pump, as it discharges a definite quantity of liquid during the displacement of its piston or plunger. Reciprocating Pump is best suited for relatively small capacities and high heads.

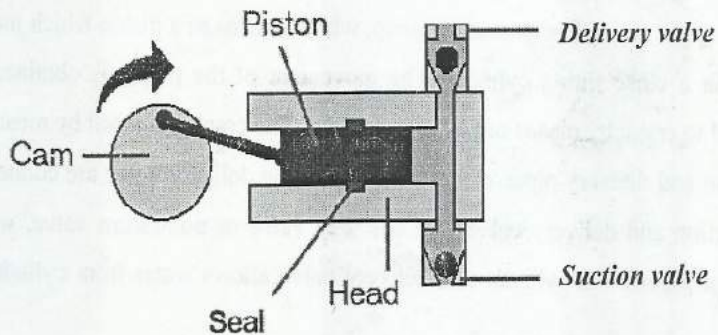

Main parts of a Reciprocating pump:

1. A cylinder with a piston, piston rod, connecting rod and a crank,
2. Suction pipe,
3. Delivery pipe,
4. Suction valve, and
5. Delivery valve.

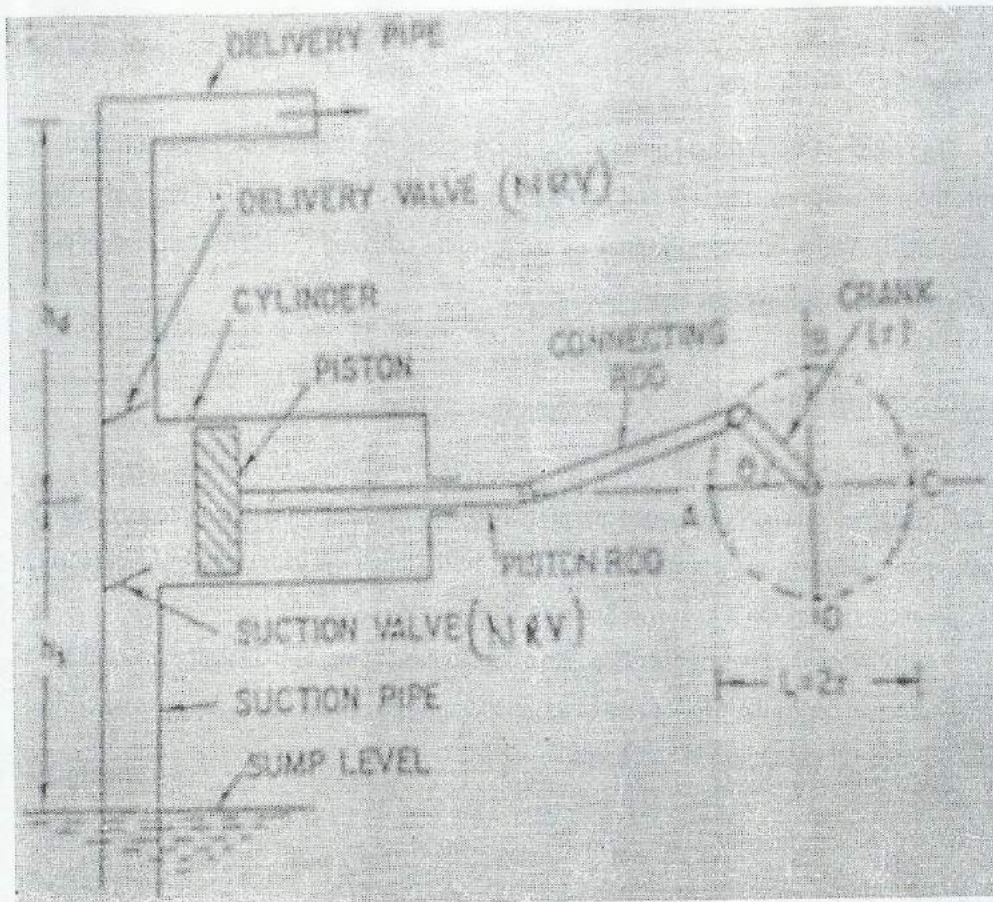

Working of a Reciprocating pump:

Figure shows a single acting Reciprocating pump, which consist of a piston which moves backward and forward in a close fitting cylinder. The movement of the piston is obtained by connecting the piston rod to crank by means of a connecting rod. The crank is rotated by means of an electric motor. Suction and delivery pipes with suction valve and delivery valve are connected to the cylinder. The suction and delivery valves are one way valve or non-return valve, which allow water from suction pipe to the cylinder and delivery valve allows water from cylinder to delivery pipe only.

When crank starts rotating, the piston moves to and fro (backward and forward) in the cylinder. When crank is at A, the piston is at the extreme left position in the cylinder. As a crank rotating from A to C, (i.e. 0° to 180°), the piston is moving towards right in the cylinder. The movement of the piston towards right creates a partial vacuum in the cylinder. But on the surface of the liquid in the sump atmospheric pressure is acting, which is more than the pressure inside the cylinder. Thus the liquid is forced in the suction pump from the sump. This liquid opens the suction valve and enters the cylinder.

When crank is rotating from C to A, (i.e. 180° to 360°), the piston is moving from its

extreme position starts moving towards left in the cylinder. The movement of the piston towards left increase the pressure of the liquid in the cylinder more than atmospheric pressure. Hence suction valve closes and delivery valve opens. The liquid is forced in to the delivery pipe and raised to a required height.

Advantages of Centrifugal Pump over Reciprocating Pump.

S.No	<i>Centrifugal Pump</i>	<i>Reciprocating Pump.</i>
1	Smooth and even flow.	Pulsating flow.
2	Low initial cost.	Initial cost as high as four times that of Centrifugal pump.
3	Compact, occupies less floor space	Occupies 6 to 8 times the space required for horizontal centrifugal pump
4	Gross weight is small	Gross weight is considerable.
5	Installation is easy.	Installation is more difficult than Centrifugal pump.
6	Efficiency of low head pump is high	Efficiency of low head pumps may be as low as 40 % chiefly because of relatively higher energy losses viz. frictional, valve losses etc.
7	Construction is simplified by elimination of many parts such as non return valves, glands, air vessel etc. Therefore less number of space parts are required.	Complicated construction. Therefore a numbers of spare parts are necessary.
8	Low maintenance cost. Periodical check-up is sufficient.	Maintenance charges are high because parts like valves require constant attention.
9	High speed. Can be coupled directly through flanged coupling to electric Motors or steam turbines.	Low speed due to separation difficulties. Belt drive indispensable.
10	Uniform Torque.	Torque not uniform.
11	Easy handling of highly viscous fluid oils, muddy and sewage water, chemicals, etc	Valve and glands cause trouble when required to transmit

Advantages of Reciprocating Pump over the Centrifugal Pump:

1. The reciprocating pump can built up very high pressure, upto 700 kg/cm² or even more.
2. The efficiency of reciprocating pump is more than that of centrifugal pump to handle small discharge at a high head. It may be as high as 90%.

Discharge of reciprocating Pump: $Q = \frac{LAN}{60}$ (For single acting)

and $Q = \frac{2LAN}{60}$ (For double acting)

PRIMING DEVICES

Before starting a centrifugal pump it must be primed, small pumps are usually primed by pouring the liquid through a funnel into the casing from some external sources. The air vent provided in the casing is opened to facilitate the exit of the air, when all the air has been removed from the suction pipe and the pump casing, the air vent is closed and the pump is primed.

Large pumps are usually primed by evacuating the casing and the suction pipe with the aid of an air pump or a steam ejector, the liquid is thus sucked into the suction pipe from the pump.

In some pumps, their internal construction is such that special arrangements containing a supply of liquid are provided in the suction pipe, which facilitate automatic priming of the pump. Such pumps are known as self-priming pumps.

HYDRAULIC DEVICES

These are some hydraulic machines in which the liquid (water or oil) acts as a medium of transmission of power or pressure based on the principles of hydrostatics and hydraulics

1. The Hydraulics Press
2. The Hydraulics Accumulator
3. The Hydraulics Intensifier
4. The Hydraulics Ram
5. The Hydraulics Crane
6. The Hydraulics Lift